



# NLEvo

BESPOKE,  
EFFICIENT &  
ERGONOMIC



Nestled quietly within the heart of Monaco is our small, but perfectly formed factory, hand-crafting espresso machines since 1956. We combine a genuine passion for innovation and coffee excellence, with exceptional quality and reliability to produce the finest machines for any circumstance or environment.

[www.conti-espresso.com](http://www.conti-espresso.com)

ESTD 1956  
  
**Conti**  
MONACO

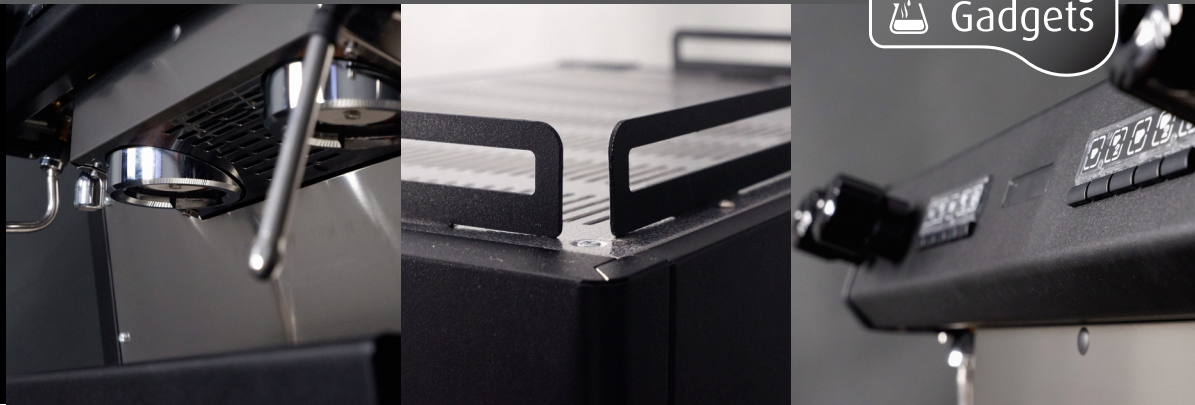

The NL EVO is our simple, yet effective model designed for low to mid volume environments when something bespoke and unique is required.

Built around the fundamentals of our CC100 range, the NL EVO is technology packed, built to last and offers the perfect solution for those special multi-site projects.



**Cohesive Design**

We wanted the NL EVO to transition itself into any environment, keeping the design pure and clean, whilst creating an ergonomic tool for crafting a variety of drinks day in, day out. Available in 1 group, 2 group compact or standard 2 group with LED DISPLAY, this range is versatile and appeals to all.



**Tall Cup**

No matter which configuration you choose, the NL EVO is available in Tall Cup format at no additional cost, making takeaway service simple and efficient.



**Adjustable Temperature Using P.I.D.**

Control espresso extraction temperature and perfectly match machine to bean, to encourage consistency and give results, shot after shot.

**Additional Features:**

**Eco Mode**

Utilising our Eco mode, reduce your power consumption by up to 40% overnight or when closed.

**Auto Cleaning**

Never use a dirty machine again, simple to operate, helps to ensure your machine is 'always sparkling clean'.

**Compact Model**

Designed to squeeze into tight spaces whilst still packing a massive punch of performance.

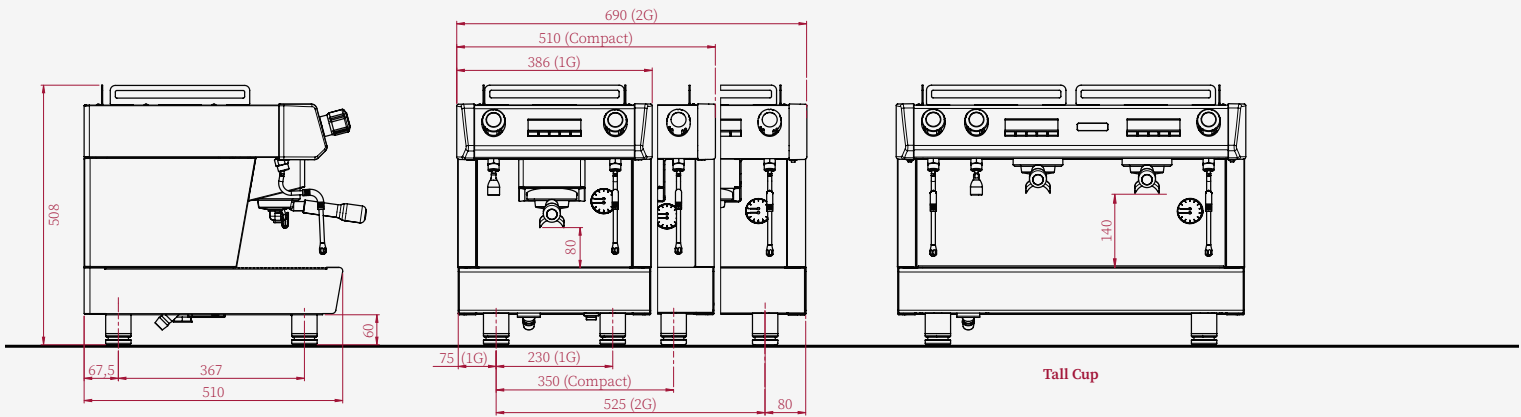

	1 Group	2 Group Compact	2 Group
Height (mm)	508	508	508
Width (mm)	386	510	690
Depth (mm)	510	510	510
Weight (kg)	40	51	58
Steam Boiler Size (Litres)	5	7	11
Coffee Boiler Size (Litres)	n/a	n/a	n/a
Group Element (W)	n/a	n/a	n/a
Steam Boiler Element (W)	2500	2400	2850/3300
Coffee Boiler Element (W)	n/a	n/a	n/a
Total Power (W)	2700	2600	3050/3500
Voltage (V)	230	230	230

**Colour Options:**



Jet Black Textured Finish